

**NOTES:**

1. 1,000 lbs. WORKING LOAD IN VERTICAL DIRECTION.
2. ASSEMBLY SHOWN IS 1-BAR SLEEVE DESIGN. WORKER'S LIFELINE TO BE TIED TO INDEPENDENT ANCHOR.
3. MAXIMUM CANTILEVER DISTANCE (L1) IS 30".

**IMPORTANT:**

1. RIGGING SLEEVES ARE DESIGNED TO A TYPICAL SUSPENSION WORKING LOAD OF 1,000 lbs. (4.5 kN), WITH A FACTOR OF SAFETY OF 4 AGAINST FRACTURE OR DETACHMENT.
2. IT IS THE RESPONSIBILITY OF THE STRUCTURAL ENGINEER FOR THE OVERALL PROJECT TO ENSURE THAT THE STRUCTURE ON WHICH THE SAFETY EQUIPMENT BY PRO-BEL IS INSTALLED, IS REINFORCED TO WITHSTAND THE LOADS INDICATED ON THIS DRAWING.

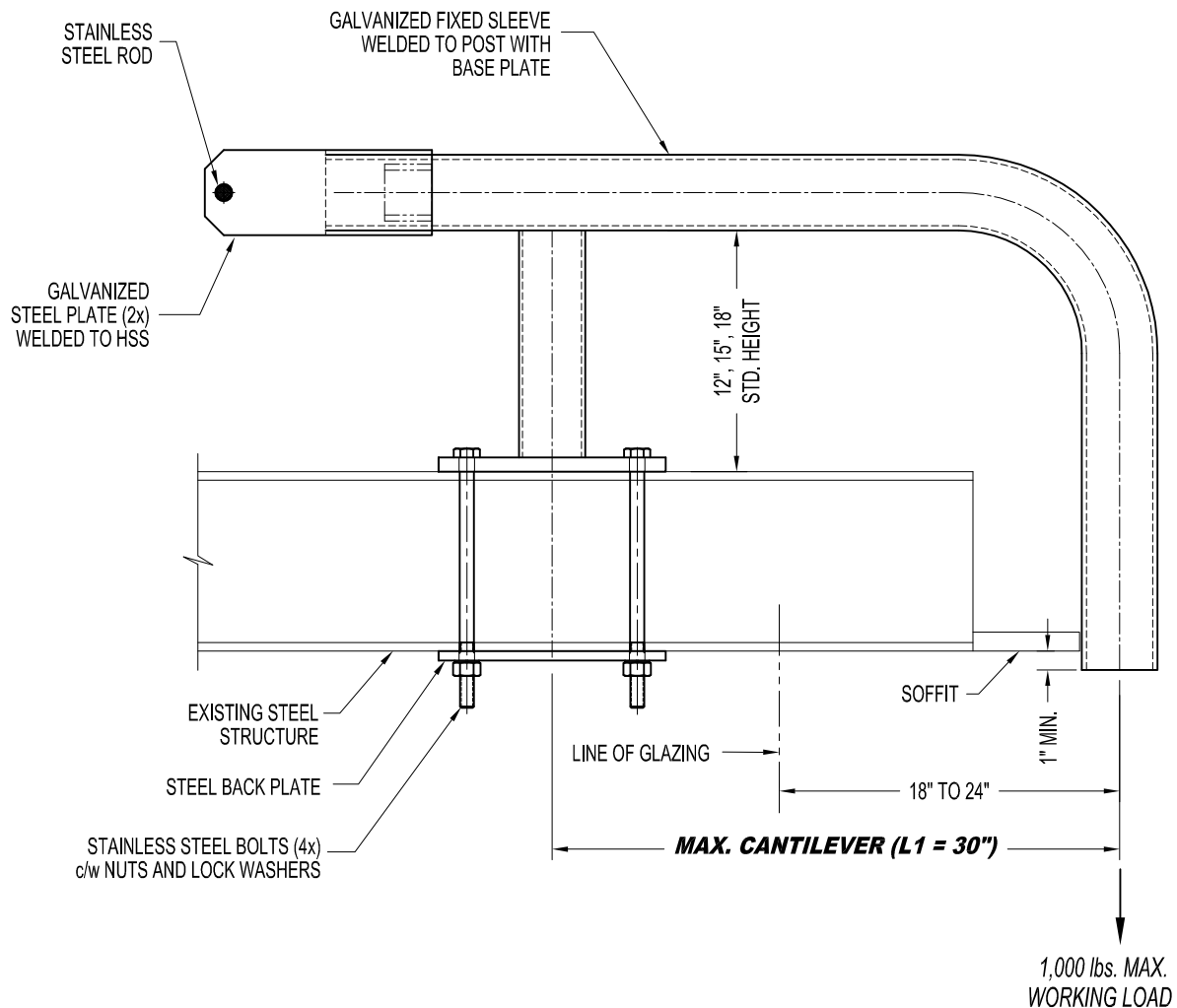

**A-RSC14141: WRAP AROUND STEEL - CURVED RIGGING SLEEVE (4" O.D. FIXED SLEEVE)**

**NOTES:**

1. 1,000 lbs. WORKING LOAD IN VERTICAL DIRECTION.
2. ASSEMBLY SHOWN IS 1-BAR SLEEVE DESIGN. WORKER'S LIFELINE TO BE TIED TO INDEPENDENT ANCHOR.
3. MAXIMUM CANTILEVER DISTANCE (L1) IS 30".

**IMPORTANT:**

1. RIGGING SLEEVES ARE DESIGNED TO A TYPICAL SUSPENSION WORKING LOAD OF 1,000 lbs. (4.5 kN), WITH A FACTOR OF SAFETY OF 4 AGAINST FRACTURE OR DETACHMENT.
2. IT IS THE RESPONSIBILITY OF THE STRUCTURAL ENGINEER FOR THE OVERALL PROJECT TO ENSURE THAT THE STRUCTURE ON WHICH THE SAFETY EQUIPMENT BY PRO-BEL IS INSTALLED, IS REINFORCED TO WITHSTAND THE LOADS INDICATED ON THIS DRAWING.

